

RoHS

本产品符合我司QA-3-04-005
环境管理物质标准规范

包装图

包装说明:

Packaging Instruction.

步骤1: 将检验好之产品依包装数量装入PE袋中, 然后将PE袋封好并贴上标签.

Step 1: Pack all the passed goods into PE bag. And then stick label on the PE bag.

步骤2: 将装好产品的PE袋依数量整齐摆放装入纸箱中. 包扎带包扎好.

Step 2: Step 2: Line up all PE bags with products.

步骤3: 用透明胶把纸箱封好并在纸箱上贴上标签, 再用.

Step 3: Seal the carton and stick label on the carton, then bind up.

注: 尾数可用填充物填充.

PS: If there is room, it can be filled with other stuff to keep the carton full.

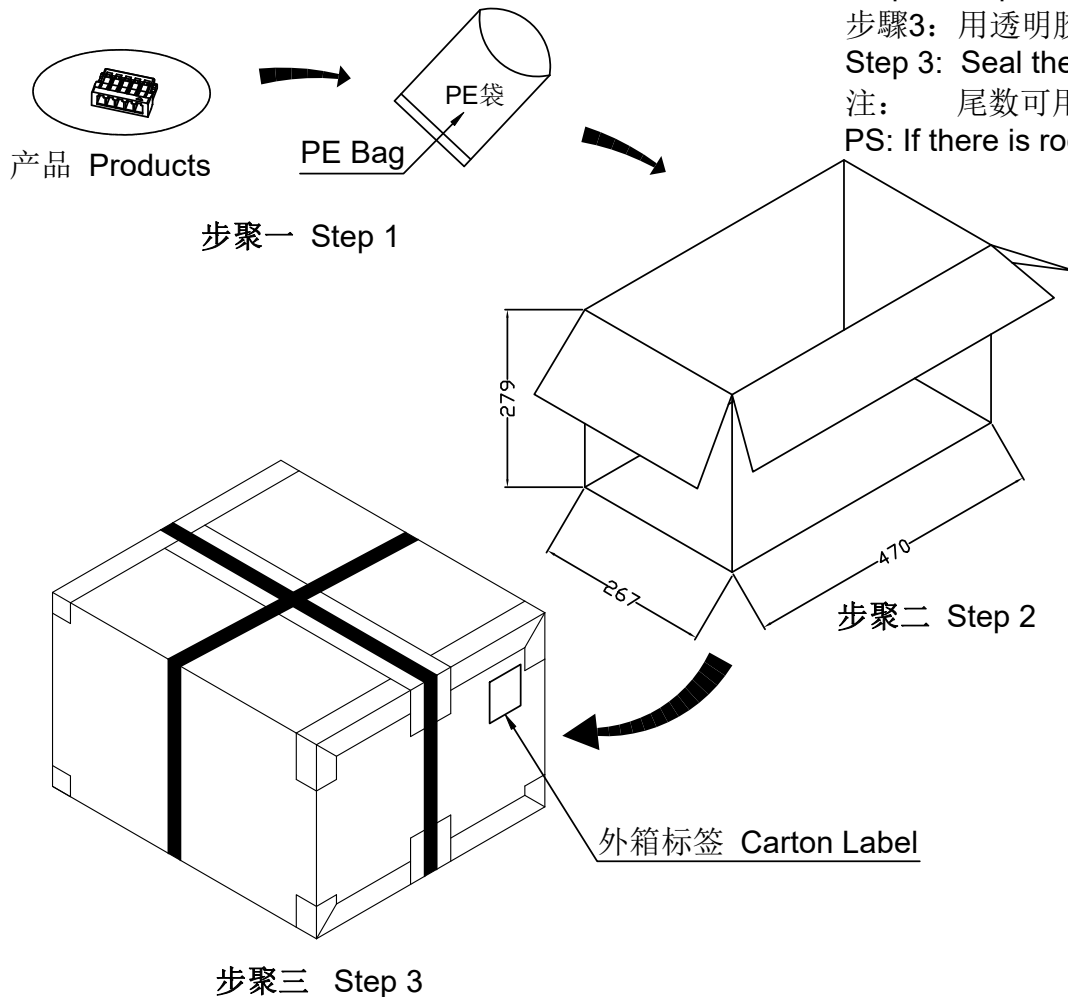

Part No.	PIN	PE Bag	Carton	
		PCS/PE	CARTON Bag	CARTON PCS
0800H-02	02	1000	500	500,000
0800H-03	03	1000	450	450,000
0800H-04	04	1000	400	400,000
0800H-05	05	1000	350	350,000
0800H-06	06	1000	300	300,000
0800H-07	07	1000	250	250,000
0800H-08	08	1000	200	200,000
0800H-09	09	1000	150	150,000
0800H-10	10	1000	100	100,000

						一般公差 .X ±0.30 .XX ±0.20 .XXX ±0.10 X° ±0.2°				东莞市翰皓精密电子有限公司 DONGUAN HANHAO PRECISION ELECTRONIC CO.,LTD				料号: J0800H-XX 名称: 0.80mm Housing Packing			
2020.06.04	B	EN20200409001	Update Drawing Frame	YYting	Robing	核准	审查	制作	日期								
日期	版次	变更编号	变更内容说明	变更人	核准	Robing	YYting	Mali	2019.08.08	单位	比例	页次	版本	编号			
										mm	1:1	1/1	B	A-022			

RoHS

本产品符合我司QA-3-04-005
环境管理物质标准规范

包装图

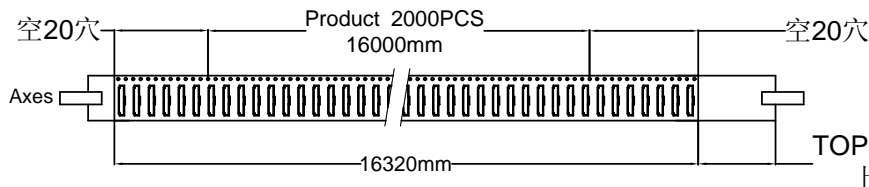

TOP TAPE 200mm
上带 200mm

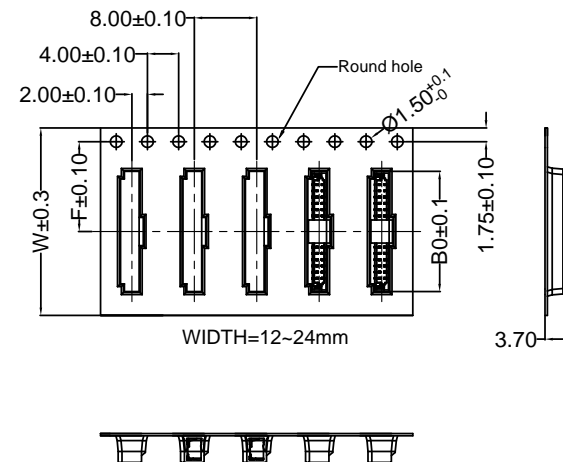

COVER TAPE PEEL STRENGTH: 20~120g
剥离力量 20~120g
速度 PEEL SPEED: 300mm/minute

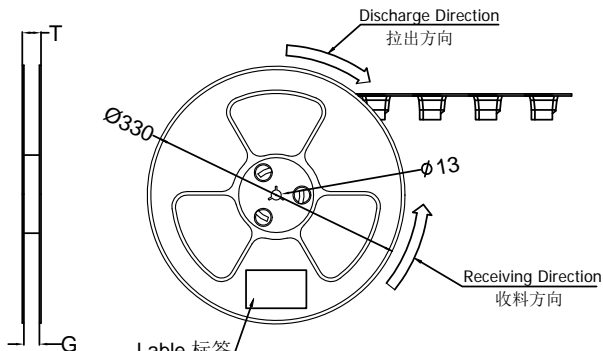

Lable 标签
Single hole: None Hole Side
单孔: 贴无链孔侧
Double hole: Elliptical Hole Side
双孔: 贴椭圆孔侧

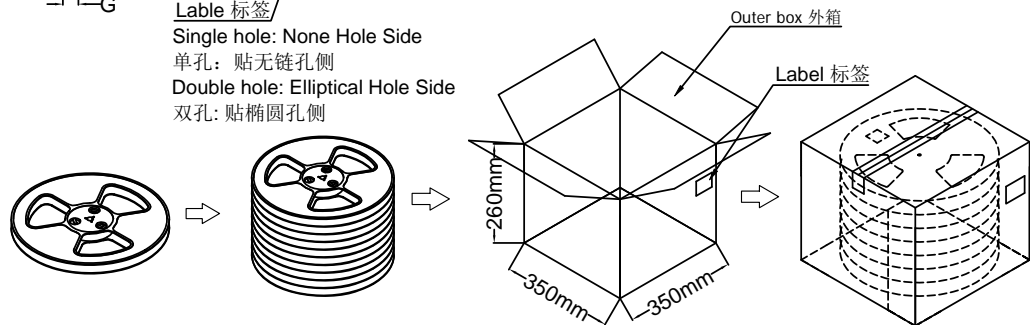

Note:

- Carrier Camber Is Within 1mm In 100mm ; 带长100mm内容许弯曲度1mm
- 10 Sprocket Hole Pitch Cumulative Tolerance±0.2MM ; 圆孔十个孔距离累计允许公差为±0.2mm
- Material for PS Black ; 材质为PS材质 Color颜色: Natural透明色
5. bracer保护带: Color颜色:Natural透明色;厚度0.40mm最小
- 6.Thickness=0.30±0.05 ; 材料厚度为0.30±0.05mm
- 7.Cover Tape上带: 冷封

Pin No.	W	S	F	T	G	Carrier Tape (Color) 下带 (颜色)	B0	REEL PCS	CARTON R	CARTON PCS
J0800WS-02						黑色	4.20	2000	13	26K
J0800WS-03	12.0	/	5.50	16.50	12.50		5.00			
J0800WS-04							5.80			
J0800WS-05							6.60	2000	11	22K
J0800WS-06	16.0	/	7.50	20.50	16.50		7.40			
J0800WS-07							8.20			
J0800WS-08							9.00			
J0800WS-09							9.80			
J0800WS-10							10.60			
J0800WS-11							11.40	2000	8	16K
J0800WS-12	24.0	/	11.50	28.50	24.50		12.20			
J0800WS-13							13.00			
J0800WS-14							13.80			
J0800WS-15							14.60			

						<p>一般公差</p> <p>.X ±0.30</p> <p>.XX ±0.20</p> <p>.XXX ±0.10</p> <p>X° ±0.2°</p> <p>视角</p>				<p>东莞市翰皓精密电子有限公司</p> <p>DONGUAN HANHAO PRECISION ELECTRONIC CO.,LTD</p>				<p>料号: J0800WS-XX</p> <p>名称: 0.80mm SMT 180° Package</p>				
2020.3.25	B	EN20200519001	Update Drawing Frame	YYting	Robing	核准	审查	制作	日期	Robing	YYting	sylyvia	2016/08/15	单位	比例	页次	版本	编号
日期	版次	变更编号	变更内容说明	变更人	核准	Robing	YYting	sylyvia	2016/08/15	mm	1:1	1/1	B	A-106				

RoHS

本产品符合我司QA-3-04-005
环境管理物质标准规范

包装图

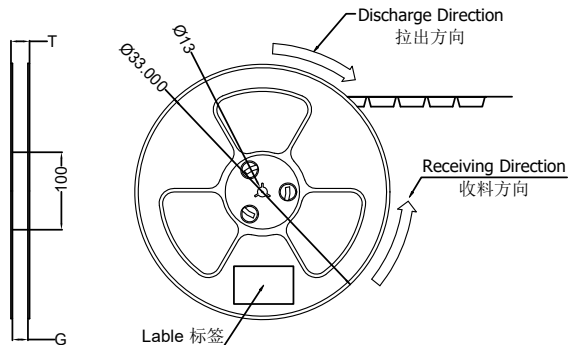
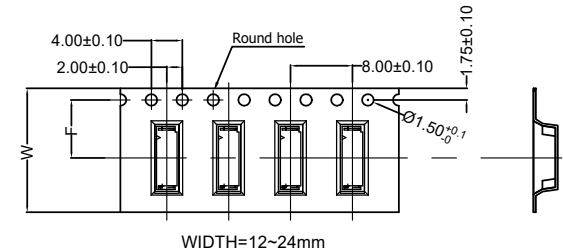
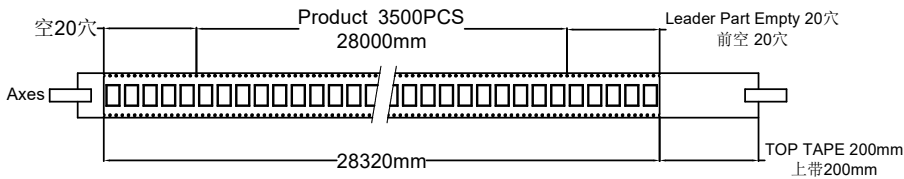

COVER TAPE PEEL STRENGTH:20~120g
上带剥离力量:20~120g
速度 PEEL SPEED:300mm/minute

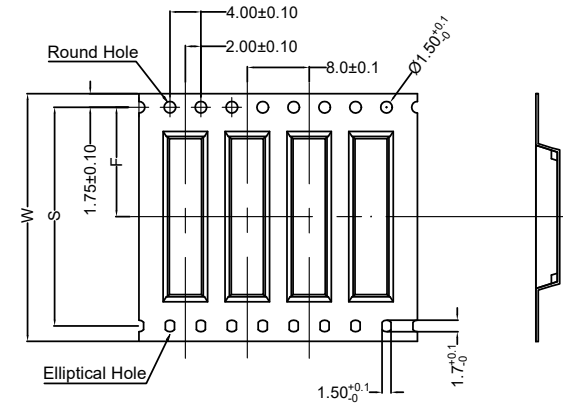
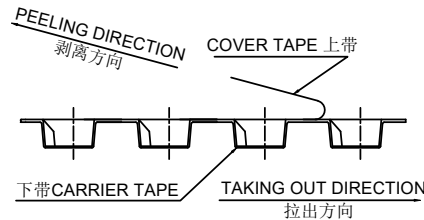

Lable 标签
Single hole: None Hole Side
单孔: 贴无链孔侧
Double hole: Elliptical Hole Side
双孔: 贴椭圆孔侧

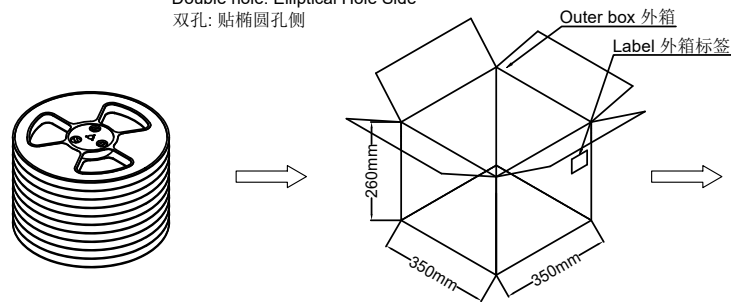

Note:

- Carrier Camber Is Within 1mm In 100mm ; 带长100mm内容许弯曲度1mm
- 10 Sprocket Hole Pitch Cumulative Tolerance±0.2MM ; 圆孔十个孔距离累计允许公差为±0.2mm
- Carrier tape material for PS ; 下带材质为PS材质 ; Color颜色:Natural透明色
- bracer保护带: Color颜色:Natural透明色, 厚度0.40mm最小
- Thinkess=0.30±0.05 ; 材料厚度为0.30±0.05mm
- Carton material纸箱材质:K=K; Carton Thickness纸箱厚度: 6~7mm

Part No.	W	S	F	T (MAX)	G(MAX)	REEL/PCS	CARTON/R	CARTON/PCS
J0800WRS-02	16	/	7.50	20.50	16.40	3500	11R	38.5K
J0800WRS-03								
J0800WRS-04								
J0800WRS-05								
J0800WRS-06								
J0800WRS-07								
J0800WRS-08	24	/	11.50	28.50	24.40	3500	8R	28K
J0800WRS-09								
J0800WRS-10								
J0800WRS-11								
J0800WRS-12								
J0800WRS-13								
J0800WRS-14	32	28.4	14.20	36.50	32.40	3500	6R	21K
J0800WRS-15								
J0800WRS-16								
J0800WRS-17								
J0800WRS-18								
J0800WRS-19								
J0800WRS-20								

						一般公差				东莞市翰皓精密电子有限公司 DONGUAN HANHAO PRECISION ELECTRONIC CO.,LTD				料号: J0800WR-XX					
						.X ±0.30								名称: 0.80mm Connectors SMT 90° Packing					
						.XX ±0.20				核准 审查 制作 日期									
2020.6.02						.XXX ±0.10								单位 比例 页次 版本 编号					
E						X° ±0.2°				mm 1:1 1/1 E A-106									
日期		版次		变更编号		变更内容说明		变更人		核准		Robing		YYting		Allen		2013/12/09	